

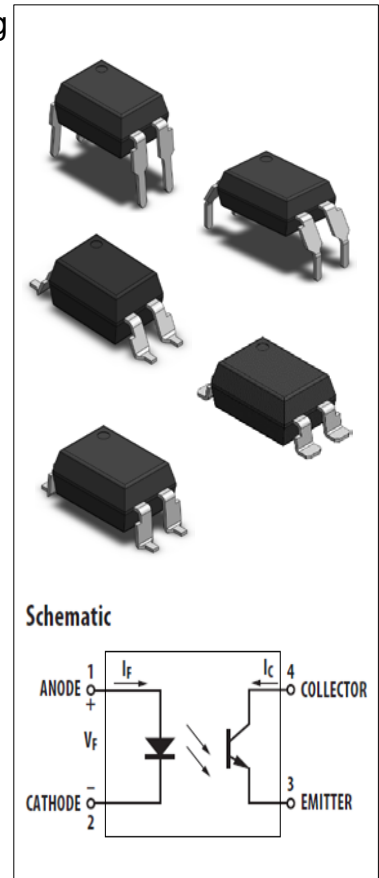

### DESCRIPTION:

The JOC817X1 photocoupler consist of an infrared light-emitting diode and a phototransistor. The devices can realize electrical isolation and signal transmission between different circuits. The products are widely used in power supply equipment, such as mobile phone charger, home appliance product power supply device, etc.



### MAIN FEATURES

- Current transfer ratio (CTR: 80%-600% @ $I_F=5mA, V_{CE}=5V$ )
- High isolation voltage between input and output ( $V_{iso}=5,000V_{rms}$ )
- Creepage distance > 7.62mm
- Operating temperature up to +110°C
- Collector-Emitter voltage  $BV_{CEO} \geq 35V$
- CQC approved
- VDE approved
- UL approved
- The products comply with RoHS, REACH and HF

### ABSOLUTE MAXIMUM RATINGS (Temperature=25°C)

Parameter		Symbol	Value	Unit
Input	Forward Current	$I_F$	60	mA
	Peak Forward Current	$I_{FP}$	1 <sup>①</sup>	A
	Reverse Voltage	$V_R$	6	V
	Power Dissipation	$P_D$	100	mW
Output	Collector-emitter Voltage	$V_{CEO}$	35	V
	Emitter-collector Voltage	$V_{ECO}$	6	V
	Collector Current	$I_C$	50	mA
	Power Dissipation	$P_C$	150	mW
Total Power Dissipation		$P_{tot}$	200	mW
Isolation Voltage		$V_{iso}$	5000 <sup>②</sup>	Vrms
Operating Temperature		$T_{opr}$	-55~+110	°C

Storage Temperature	T <sub>stg</sub>	-55~+125	°C
Soldering Temperature	T <sub>sol</sub>	260	°C

**NOTE1:** 100us pulse, 100Hz frequency

**NOTE2:** AC for 1minute, R.H.=40~60%

**ELECTRICAL CHARACTERISTICS** (Temperature=25°C)

Parameter		Symbol	Condition	Min.	Typ.	Max.	Unit
Input	Forward Voltage	V <sub>F</sub>	I <sub>F</sub> =10mA	-	1.24	1.4	V
	Reverse Current	I <sub>R</sub>	V <sub>R</sub> =6V	-	-	1	μA
	Terminal Capacitance	C <sub>t</sub>	V=0, f=1kHz	-	30	250	pF
Output	Collector-Emitter dark current	I <sub>CEO</sub>	V <sub>CE</sub> =20V, I <sub>F</sub> =0	-	-	50	nA
	Collector-Emitter breakdown voltage	BV <sub>CEO</sub>	I <sub>C</sub> =0.1mA I <sub>F</sub> =0	35	-	-	V
	Emitter-Collector breakdown voltage	BV <sub>ECO</sub>	I <sub>E</sub> =0.1mA I <sub>F</sub> =0	6	-	-	V
Transfer Characteristics	Current transfer ratio	CTR <sup>①</sup>	I <sub>F</sub> =5mA V <sub>CE</sub> =5V	80	-	600	%
	Collector-Emitter Saturation Voltage	V <sub>CE(sat)</sub>	I <sub>F</sub> =20mA I <sub>C</sub> =1mA	-	0.06	0.2	V
	Isolation resistance	R <sub>IO</sub>	DC500V 40~60%R.H.	5×10 <sup>10</sup>	10 <sup>11</sup>	-	Ω
	Floating Capacitance	C <sub>IO</sub>	V=0, f=1MHz	-	0.4	1	pF
	Cut-off Frequency	f <sub>c</sub>	V <sub>CE</sub> =5V, I <sub>C</sub> =2mA R <sub>L</sub> =100Ω, -3dB	-	80	-	kHz
	Rise Time	t <sub>r</sub>	V <sub>CE</sub> =2V, I <sub>C</sub> =2mA R <sub>L</sub> =100Ω	-	5	18	μs
	Fall Time	t <sub>f</sub>		-	4	18	μs
	Response Time	t <sub>on</sub>		9	25	μs	
t <sub>off</sub>		5		25	μs		

**NOTE1:** Rank Table of Current Transfer Ratio (Temperature=25°C)

Grade Sign	Min. (%)	Max. (%)
A	80	160
B	130	260
C	200	400
D	300	600
E	100	200
F	150	300

**ORDERING AND MARKING INFORMATION**

<b>MARKING INFORMATION</b>			
		JOC : Company Abbr. 817 : Part Number X : CTR Rank F : Leadframe Option V : VDE Option Y : Fiscal Year A : Manufacturing Code WW : Work Week	
<b>ORDERING INFORMATION</b>			
<b>JOC817X1(Y)(Z)-FGV</b>			
JOC – Company Abbr. 817 – Part Number X1 – Rank (A1/B1/C1/D1) Y – Lead Form Option (M/S/SL/None) Z – Tape and Reel Option (T1) F – Leadframe Option (F:Iron, None:Copper) G – Green V – VDE Option (V or None)			
<b>Packing Quantity</b>			
<b>Option</b>	<b>Quantity</b>	<b>Quantity – Inner box</b>	<b>Quantity –Outer box</b>
None/M	100 Units/Tube	32 Tubes/Inner box	10 Inner box/Outer box =32k Units
S(T1)/S(T2)	1500 Units/Reel	3 Reels/Inner box	5 Inner box/Outer box =22.5k Units
S(T3)/S(T4)	1000 Units/Reel	3 Reels/Inner box	5 Inner box/Outer box =15k Units
SL(T1)/SL(T2)	1500 Units/Reel	3 Reels/Inner box	5 Inner box/Outer box =22.5k Units
SL(T3)/SL(T4)	1000 Units/Reel	3 Reels/Inner box	5 Inner box/Outer box =15k Units
SLM(T1)/ SLM(T2)	1500 Units/Reel	2Reels/Inner box	5 Inner box/Outer box =15k Units

Characteristics Curves

FIG.1: Forward Current vs. Ambient Temperature

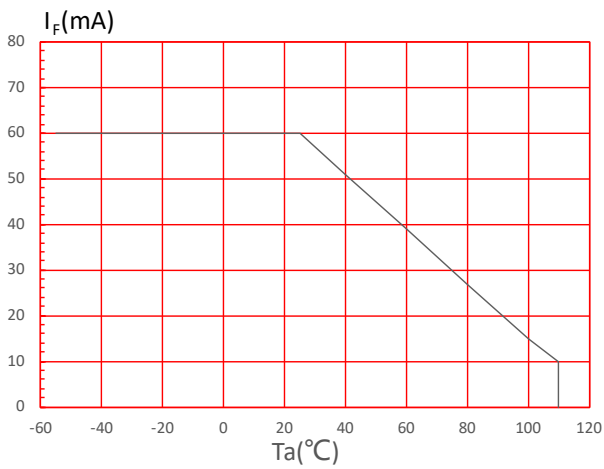

FIG.2: Collector Power Dissipation vs. Ambient Temperature

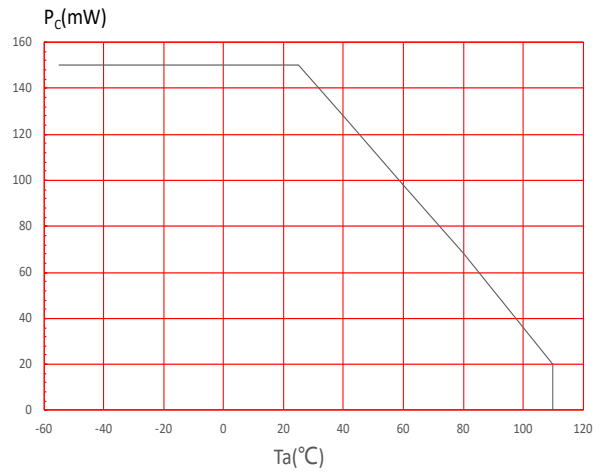

FIG.3: Forward Current vs. Forward Voltage

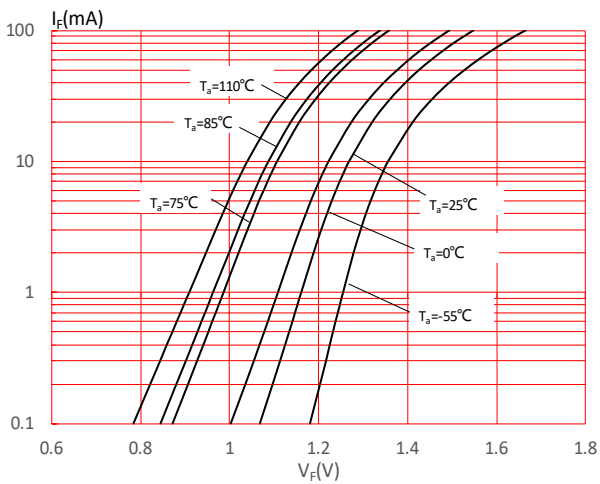

FIG.4: Collector Dark Current vs. Ambient Temperature

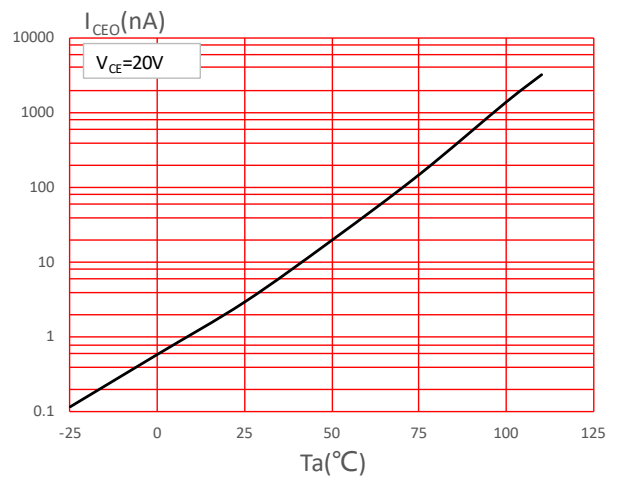

FIG.5: Collector Current vs. Collector-emitter Voltage

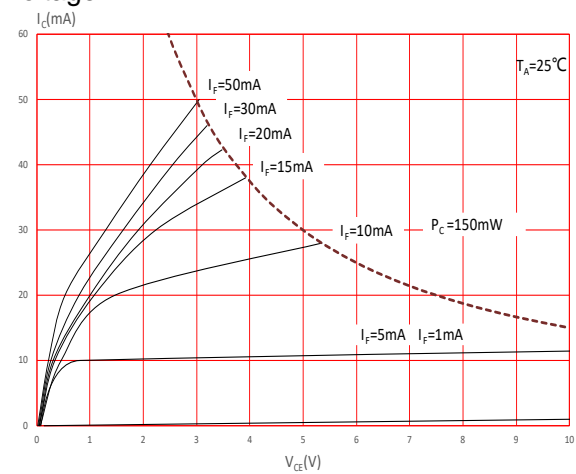
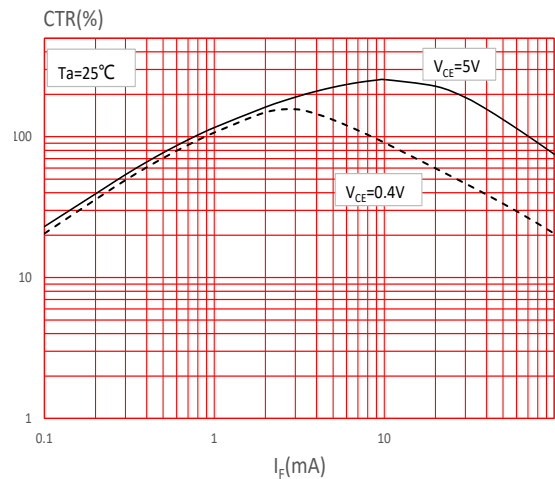
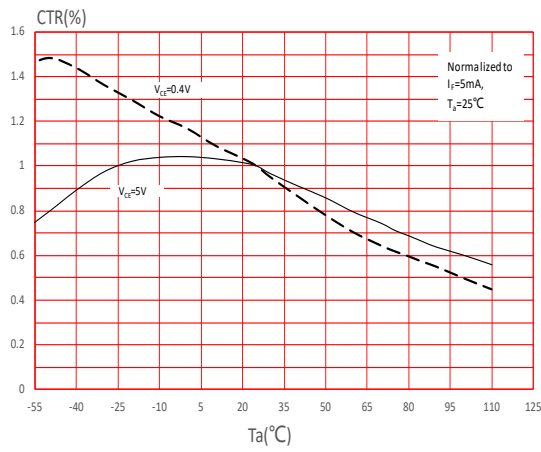

FIG.6: Normalized Current Transfer Ratio vs. Forward Current



**FIG.7:** Normalized Current Transfer Ratio vs. Ambient Temperature



**FIG.8:** Collector-emitter Saturation Voltage vs. Ambient Temperature

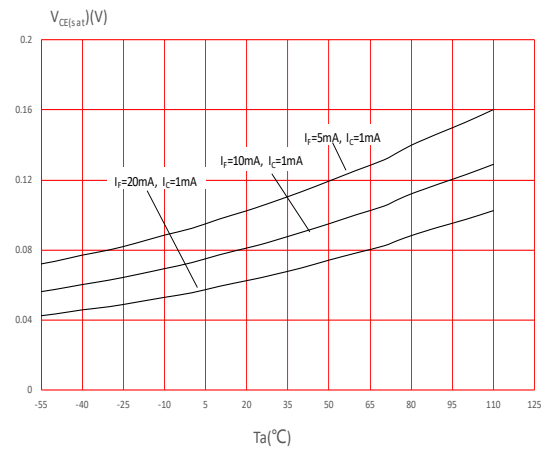

**FIG.9:** Response Time vs. Load Resistance

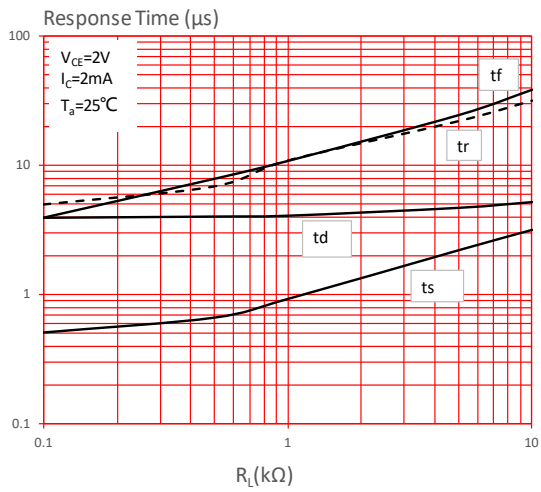

**FIG.10:** Frequency Response

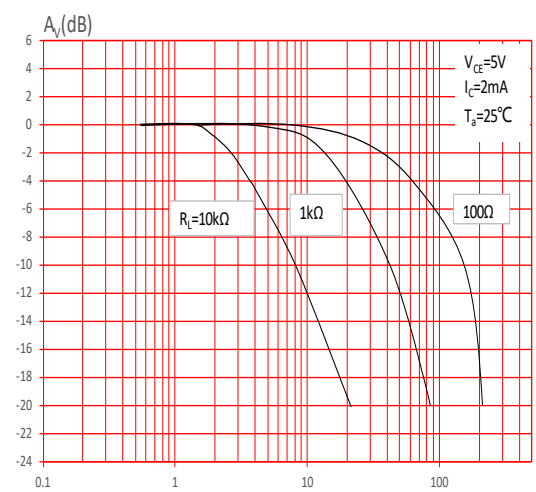

Test Circuits

FIG.11: Test Circuits of Response Time

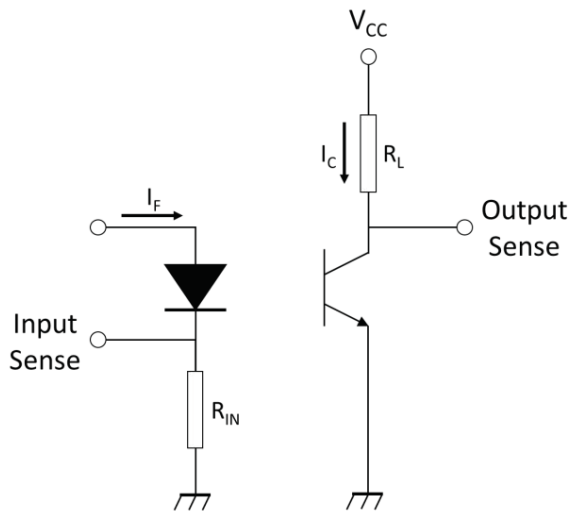

FIG.12: Curves of Response Time

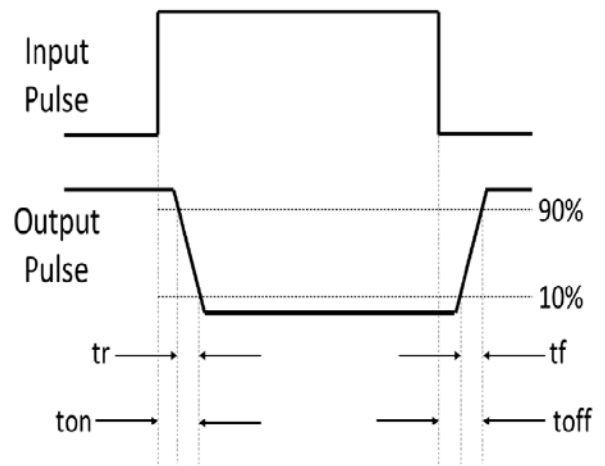
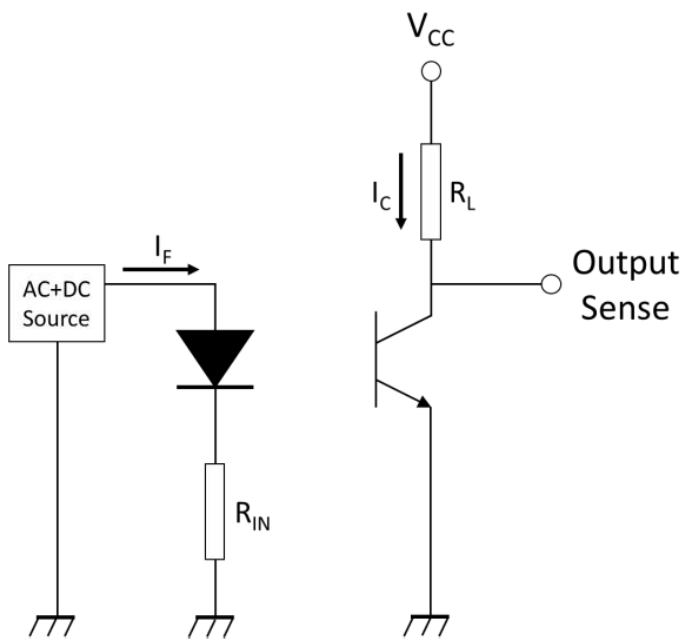
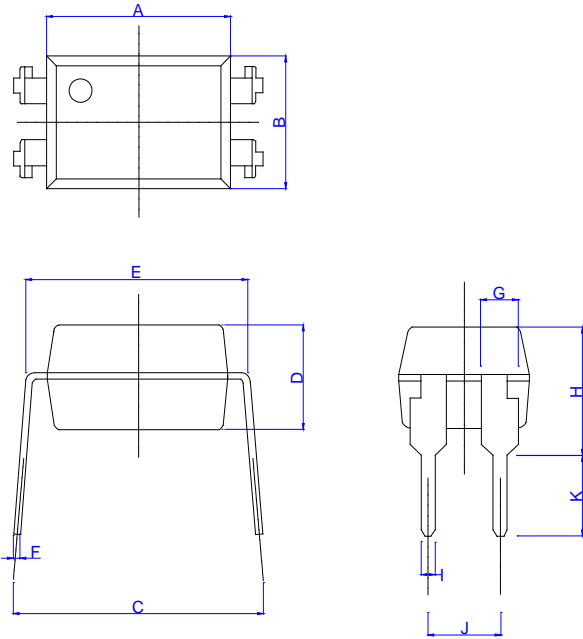

FIG.13: Test Circuits of Frequency Response



Package Dimension (Unit: mm)

Standard DIP Type:



Ref.	Dimensions					
	Millimeters			Inches		
	Min.	Typ.	Max.	Min.	Typ.	Max.
A	6.20		6.80	0.245		0.269
B	4.30		4.90	0.170		0.194
C	7.62		9.50	0.301		0.375
D	3.20		3.80	0.126		0.150
E	7.37		7.87	0.291		0.311
F		0.25			0.010	
G	1.10		1.50	0.043		0.059
H	4.20		4.80	0.166		0.190
I		0.50			0.020	
J		2.54			0.100	
K		2.80			0.111	

Option M Type:

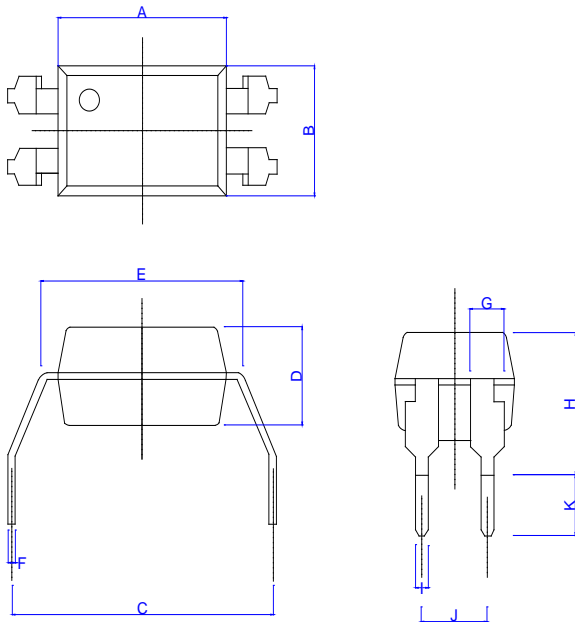

Ref.	Dimensions					
	Millimeters			Inches		
	Min.	Typ.	Max.	Min.	Typ.	Max.
A	6.20		6.80	0.245		0.269
B	4.30		4.90	0.170		0.194
C	9.90		10.50	0.391		0.415
D	3.20		3.80	0.126		0.150
E	7.37		7.87	0.291		0.311
F		0.25			0.010	
G	1.10		1.50	0.043		0.059
H	4.28		4.88	0.169		0.193
I		0.50			0.020	
J		2.54			0.100	
K		2.20			0.087	

Option S Type:

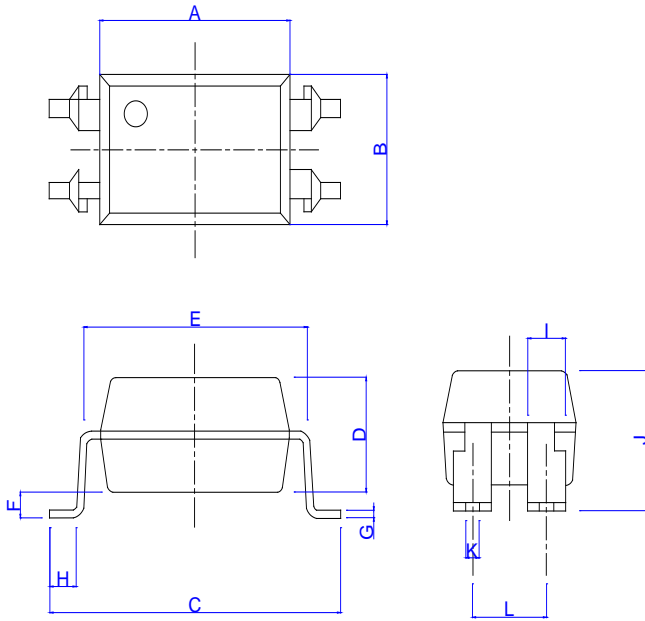

Ref.	Dimensions					
	Millimeters			Inches		
	Min.	Typ.	Max.	Min.	Typ.	Max.
A	6.20		6.80	0.245		0.269
B	4.30		4.90	0.170		0.194
C	9.90		10.50	0.391		0.415
D	3.30		3.70	0.130		0.146
E	7.32		7.92	0.289		0.313
F		0.80			0.032	
G		0.25			0.010	
H		0.80			0.032	
I	1.20		1.40	0.047		0.055
J	4.00		4.60	0.158		0.182
K		0.50			0.020	
L		2.54			0.100	

Option SL Type:

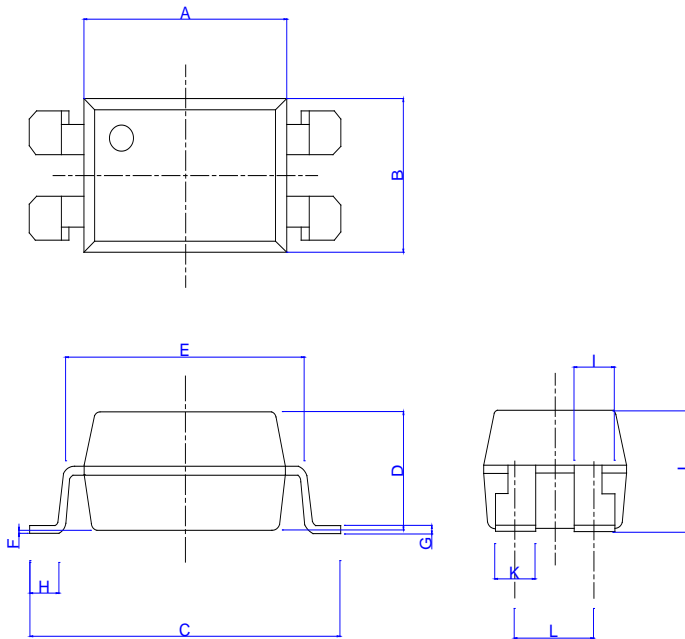

Ref.	Dimensions					
	Millimeters			Inches		
	Min.	Typ.	Max.	Min.	Typ.	Max.
A	6.20		6.80	0.245		0.269
B	4.30		4.90	0.170		0.194
C	9.90		10.50	0.391		0.415
D	3.30		3.70	0.130		0.146
E	7.32		7.92	0.289		0.313
F		0.10			0.004	
G		0.25			0.010	
H	0.50		1.10	0.020		0.043
I	1.20		1.40	0.047		0.055
J	4.00		4.60	0.158		0.182
K		1.30			0.051	
L		2.54			0.100	



Option SLM Type:

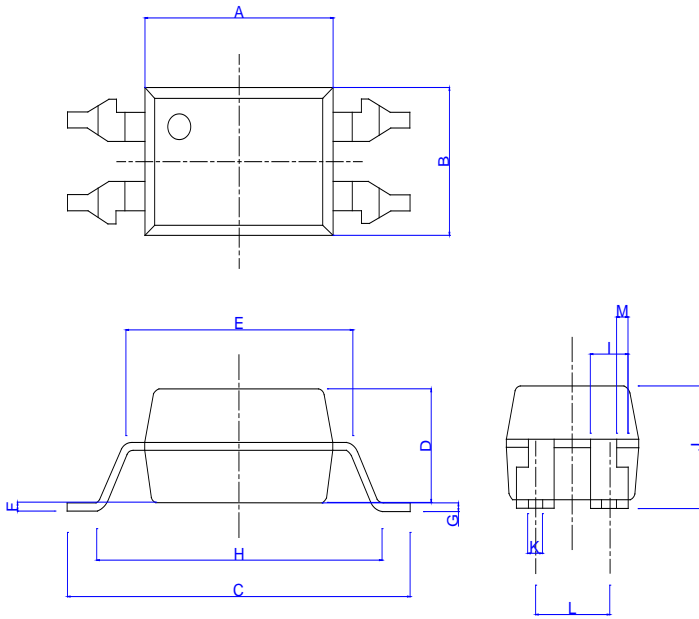

Ref.	Dimensions					
	Millimeters			Inches		
	Min.	Typ.	Max.	Min.	Typ.	Max.
A	6.20		6.80	0.245		0.269
B	4.30		4.90	0.170		0.194
C	11.50		12.10	0.455		0.478
D	3.30		3.70	0.130		0.146
E	7.32		7.92	0.289		0.313
F	0.05		0.45	0.002		0.018
G		0.25			0.010	
H	9.86		10.46	0.390		0.413
I	1.20		1.40	0.047		0.055
J	4.00		4.60	0.158		0.182
K		0.50			0.020	
L		2.54			0.100	
M	0.30		0.50	0.012		0.020

**RECOMMENDED SOLDER MASK (Dimensions in mm unless otherwise stated)**

**Surface Mount Lead Forming & Surface Mount (Low Profile) Lead Forming:**

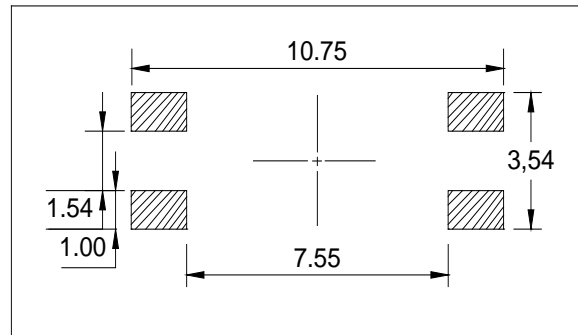

**Surface Mount (Gullwing) Lead Forming:**

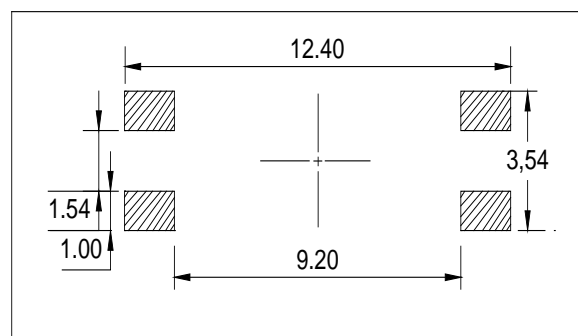

**TUBE SPECIFICATIONS (Dimensions in mm unless otherwise stated)**

**Standard DIP/M**

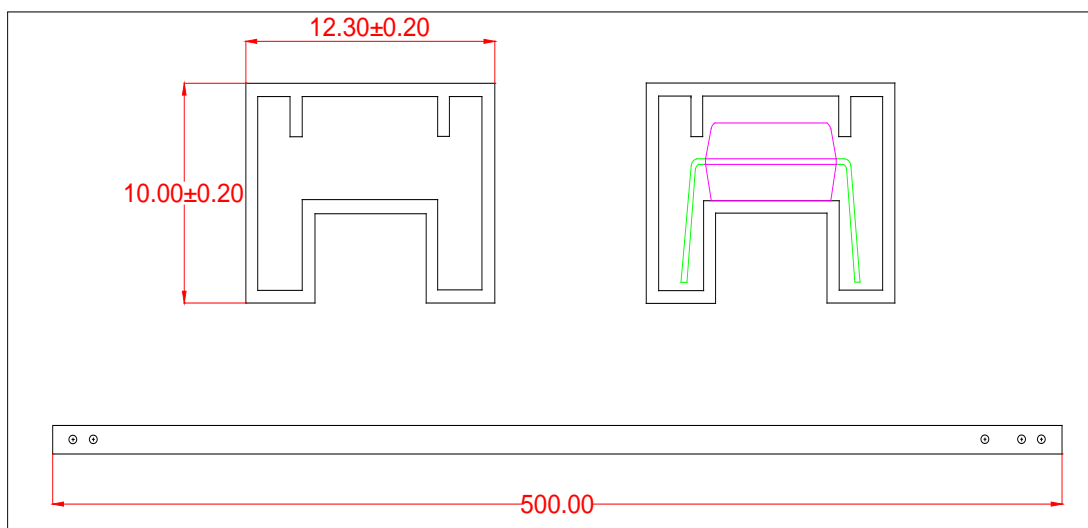

**CARRIER TAPE SPECIFICATIONS (Dimensions in mm unless otherwise stated)**

**Option S(T1) & SL(T1)**

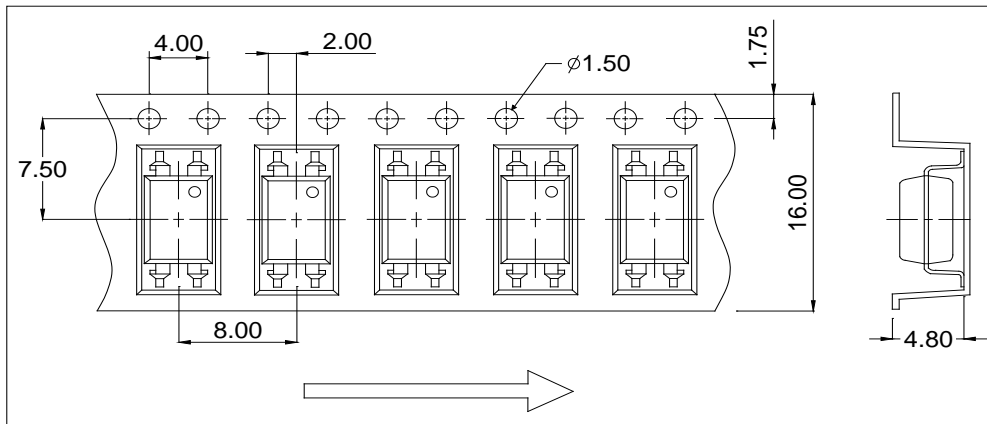

**Option S(T2) & SL(T2)**

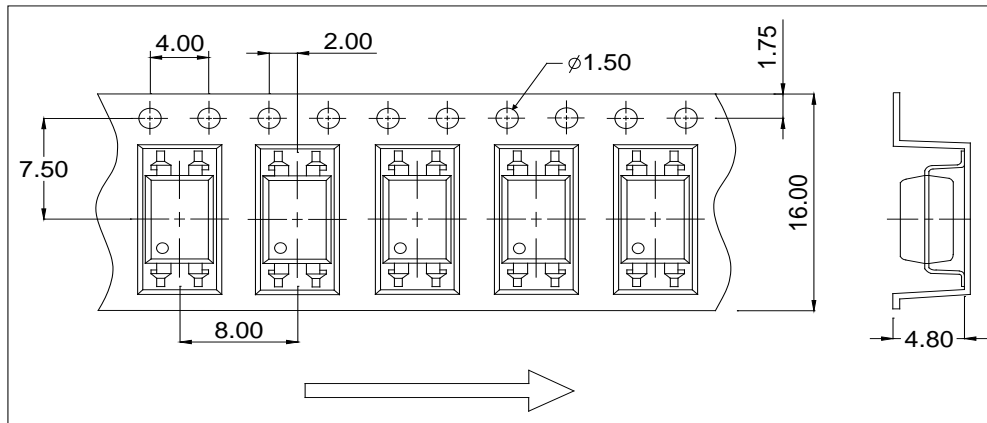

**Option S(T3) & SL(T3)**

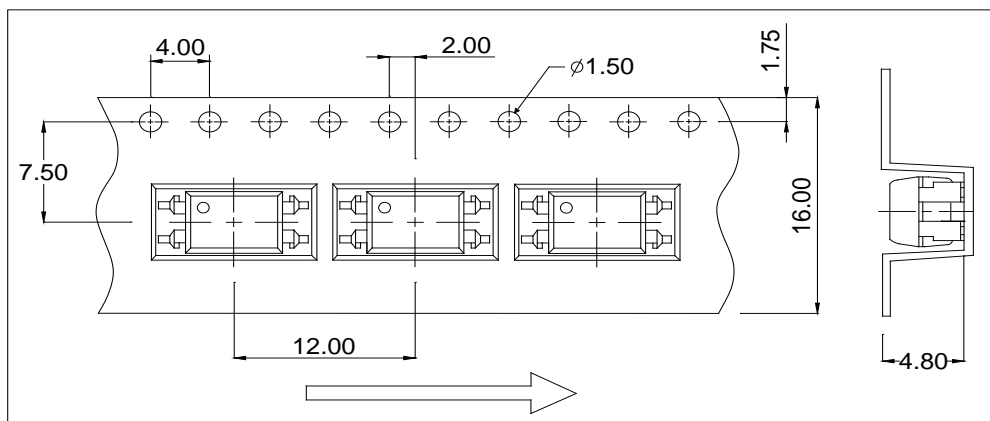

Option S(T4) & SL(T4)

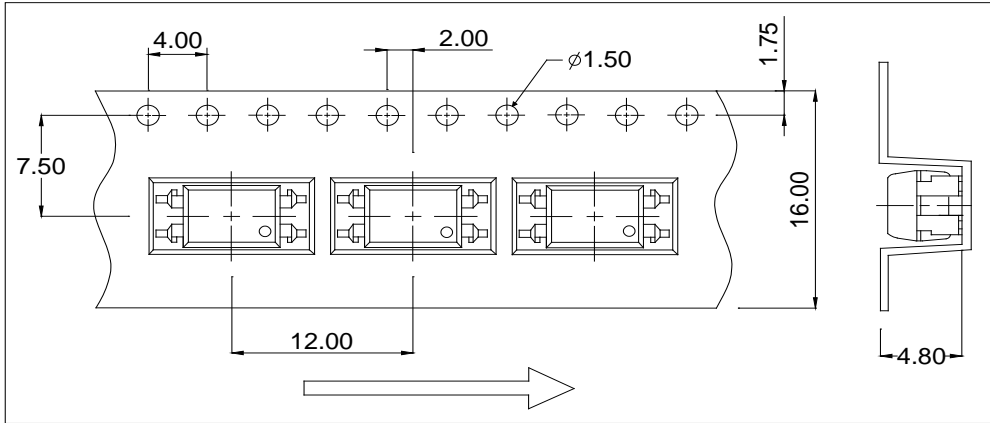

Option SLM(T1)

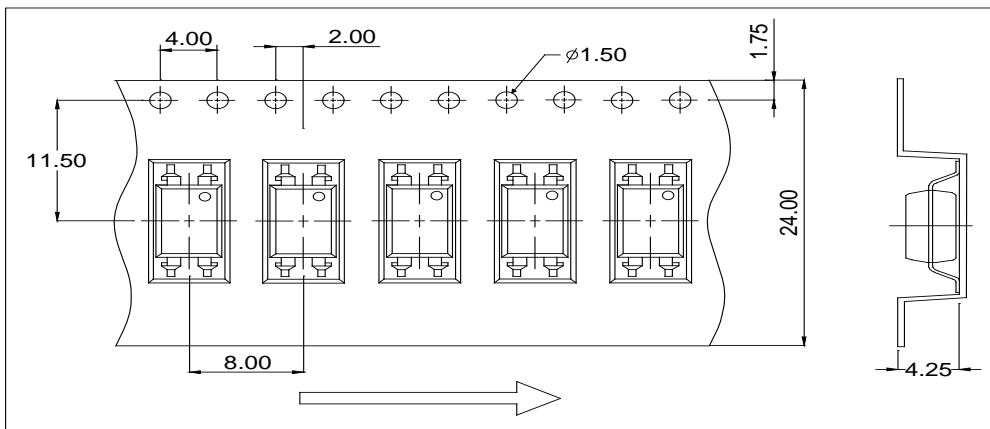

Option SLM(T2)

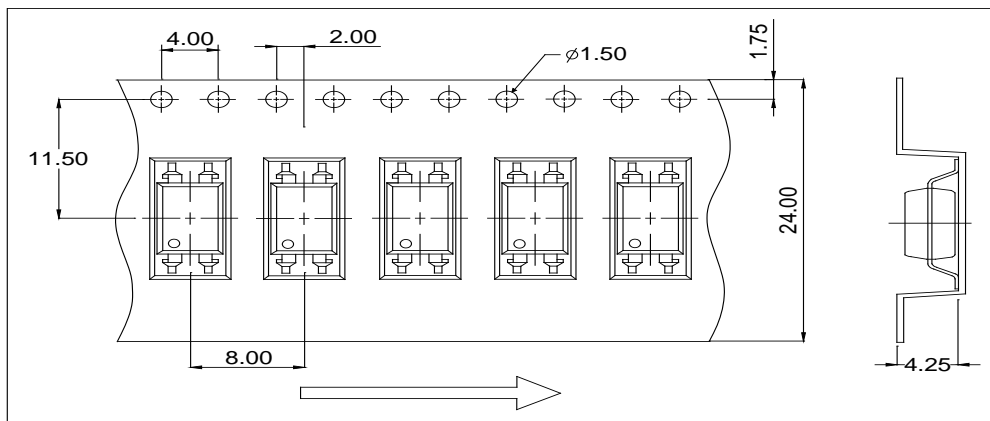

REEL SPECIFICATIONS (Dimensions in mm unless otherwise stated)

Option S & Option SL

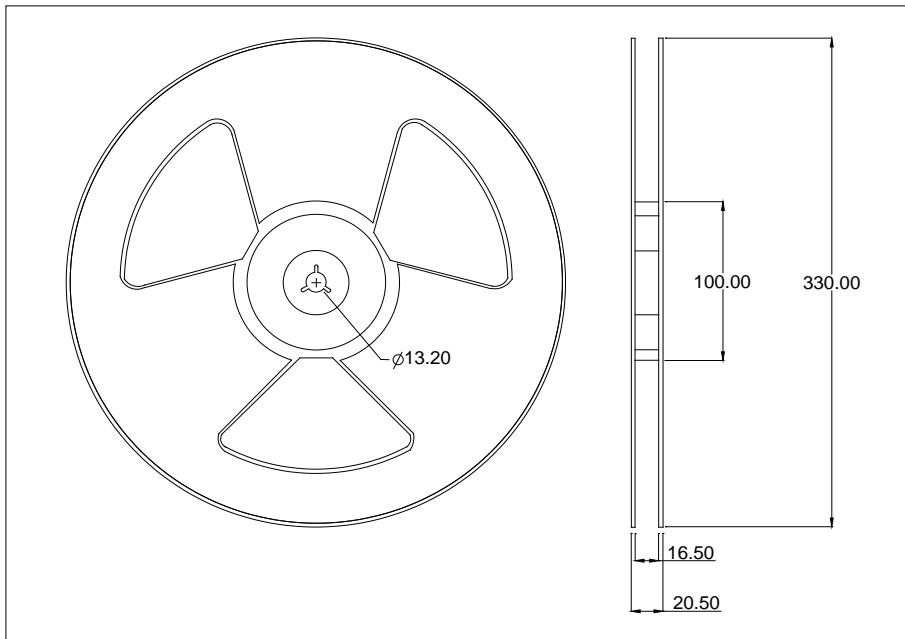

Option SLM

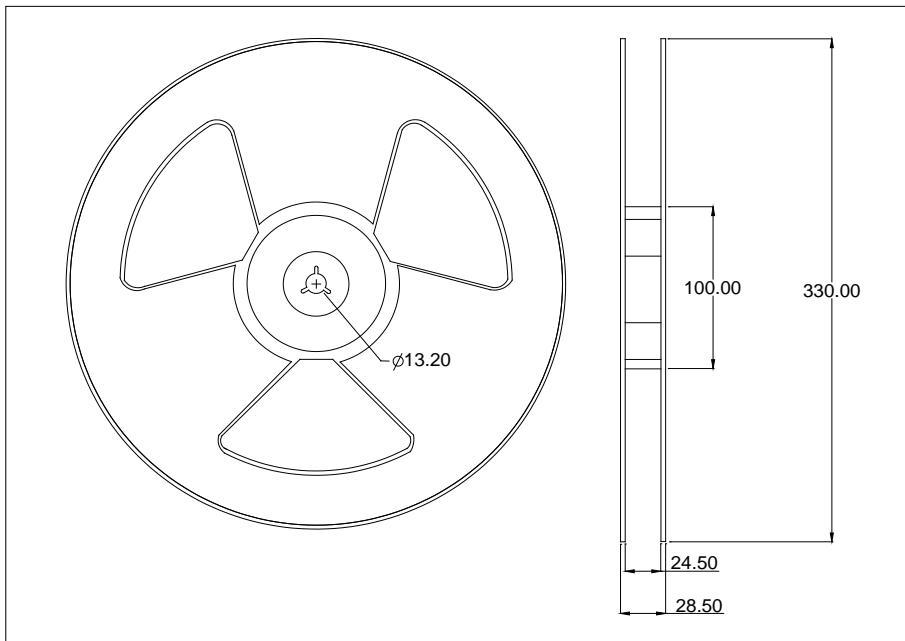

REFLOW INFORMATION

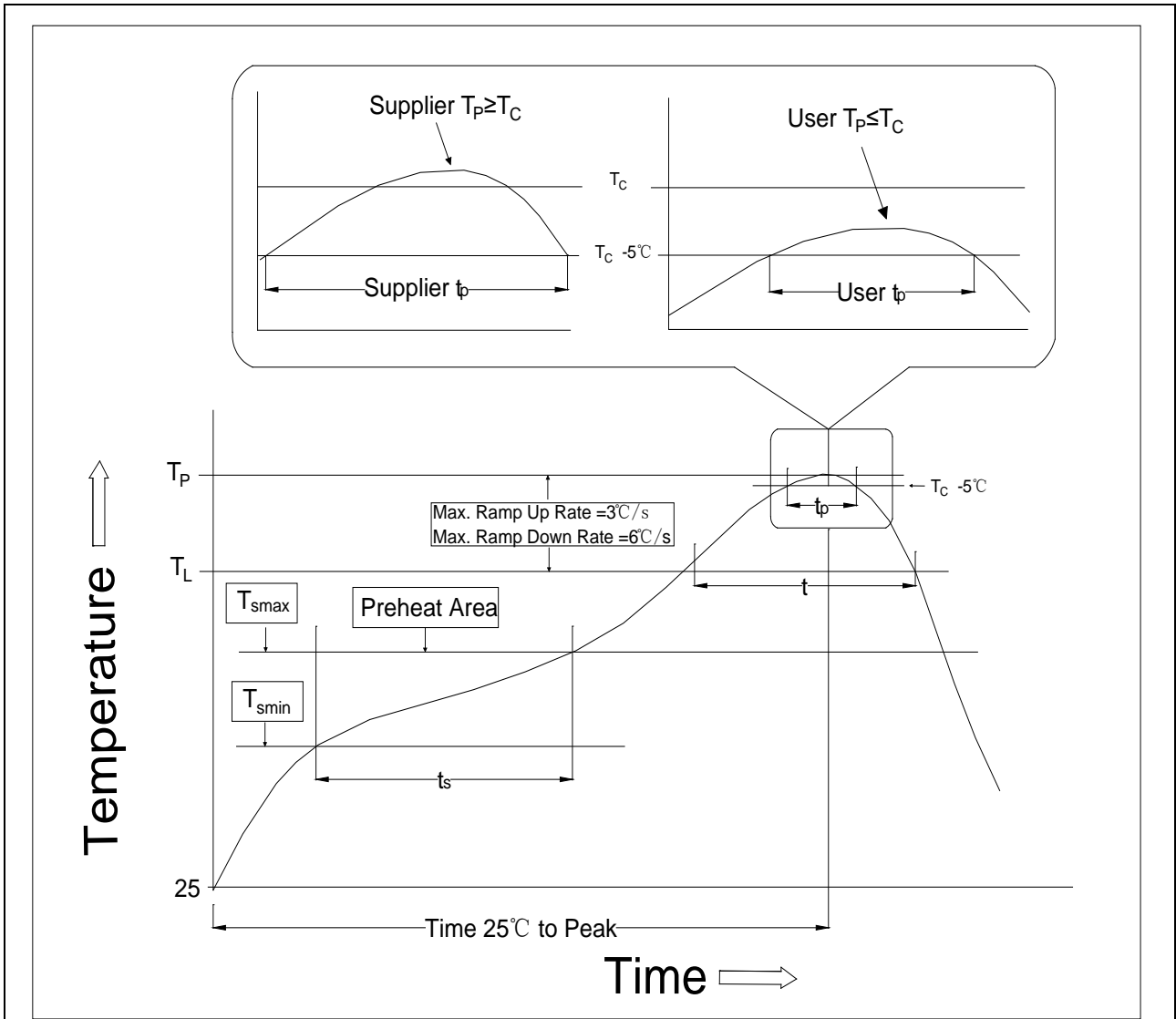

Profile Feature	Sn-Pb Assembly Profile	Pb-Free Assembly Profile
Temperature Min. (T <sub>smin</sub> )	100	150°C
Temperature Max. (T <sub>smax</sub> )	150	200°C
Time (t <sub>s</sub> ) from (T <sub>smin</sub> to T <sub>smax</sub> )	60-120 seconds	60-120 seconds
Ramp-up Rate (t <sub>L</sub> to t <sub>P</sub> )	3°C/second max.	3°C/second max.
Liquidous Temperature (T <sub>L</sub> )	183°C	217°C
Time (t <sub>L</sub> ) Maintained Above (T <sub>L</sub> )	60-150 seconds	60-150 seconds
Peak Body Package Temperature	235°C+0°C/-5°C	260°C+0°C/-5°C
Time (t <sub>P</sub> ) within 5°C of 260°C	20 seconds	30 seconds
Ramp-down Rate (T <sub>P</sub> to T <sub>L</sub> )	6°C/second max.	6°C/second max.
Time 25°C to Peak Temperature	6 minutes max.	8 minutes max.

Information furnished in this document is believed to be accurate and reliable. However, Jiangsu JieJie Microelectronics Co., Ltd. assumes no responsibility for the consequences of use without consideration for such information nor use beyond it. Information mentioned in this document is subject to change without notice, apart from that when an agreement is signed, Jiangsu JieJie complies with the agreement.

Products and information provided in this document have no infringement of patents. Jiangsu JieJie assumes no responsibility for any infringement of other rights of third parties which may result from the use of such products and information. This document supersedes and replaces all information previously supplied.

 is a registered trademark of Jiangsu JieJie Microelectronics Co., Ltd.

Copyright © 2024 Jiangsu JieJie Microelectronics Co., Ltd. All rights reserved.